

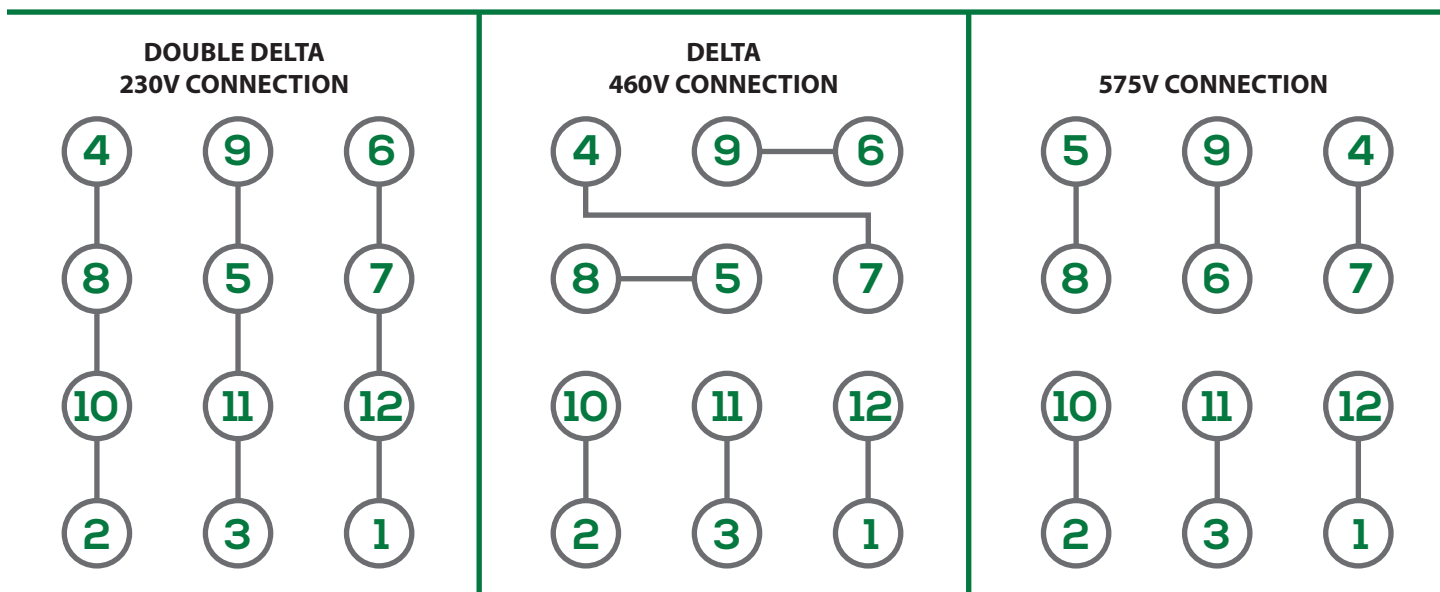

MOTOR WIRING DIAGRAM

12-LEADS CONNECTION DIAGRAMS (575 VOLTS FOR CANADIAN MARKET OR 230/460 VOLTS FOR US MARKET)



MOTOR GOOD FOR ACROSS THE LINE STARTING

Per NEMA MG1 1998-1.75, "A Part-winding Start motor is one which certain specially designed circuits of each phase of the primary winding are initially connected to the supply line. The remaining circuit or circuits of each phase are connected to the supply in parallel with initially connected circuits, at a predetermined point in the starting operation." This is intended to limit the inrush current required to start the motor. NEMA MG1 1998-14.38 states that the motor may not accelerate to full speed in part-winding and may be noisier than when on full winding.

Motors designed by BMR USA for Part-winding Start also be used for across the line starting using only the full winding connection. Damage will occur if the motor is operated with load for more than 2 seconds on Part-winding without transition to full winding.

To reverse direction of rotation, interchange leads L1 & L2.

Each lead may have one or more cables comprising that lead. In such case, each cable will be marked with the appropriate lead number.



SPECIAL INFORMATION REGARDING PART WINDING STARTING

This motor is not designed to fully accelerate when started with the part winding start connection shown on the motor connection diagram. In order to avoid damaging the motor when it is started with the part winding start connection, set timers so that the motor starter switches the motor connection from start to run within two seconds from the time that the motor is initially energized. The motor is not expected to fully accelerate before the motor connection is switched to run, but the momentary operation on the start connection should allow time for automatic voltage regulators on the power system to compensate for voltage dip resulting from the high current draw of the motor during acceleration. Thus, voltage dip in the power system will be minimized through proper use of the part winding start connection. Once the motor has been switched over to the run connection, it will finish accelerating up to full speed.

During the time that the motor is operated on the part winding start connection, it is expected that the motor may be noisier than when operated on the run connection and it is also expected that the line amp unbalance between phases may be approximately 100% to 150%. This is due to the adverse effect of harmonics that result from the unbalanced magnetic circuit on the part winding start connection.

For further information regarding characteristics of polyphase induction motors when operated on a part winding start connection, refer to NEMA Publication MG 1-1998 Part 14.38.

